

Aircraft Support Equipment



Standard features include:

- Recessed headlights
- Combination tail and stop lights
- Back-up lights
- Automatic transmission
- All hydraulic hoses rated at 2250 psi
- Non-slip surface on fenders
- Non-slip surface on brake pedal
- Engine speed governor
- Adjustable over-center park brake lever
- Conveyor lifting emergency pump
- Front, rear and side reflectors

Mobile Belt Loader Model 660

660 series: With the heaviest chassis in its class, the TUG 660 beltloader assures years of dependable service in the most demanding ramp applications. The central mounted conveyor is elevated at both ends by lift arms that are activated by single-stage, double-acting cylinders. The front of the conveyor operates at heights between 43 and 170 inches (1.09 and 4.32 m) while the height at the rear of the unit can be adjusted between 13 and 37 inches

(0.33 and 0.94 m). The unit is equipped with belt controls operable from either end of the conveyor and an interlock prevents the engine throttle from being advanced for adjustment of belt speed unless the Direction Control is in neutral. A guide on each side of the conveyor assembly can be retracted if a clear conveyor surface is required. A collapsible safety rail is fitted on the side of the conveyor and an emergency hydraulic pump is standard equipment.



VICTORY GROUND SUPPORT EQUIPMENT
(323) 581-7272 www.victorygse.com



TUGTM

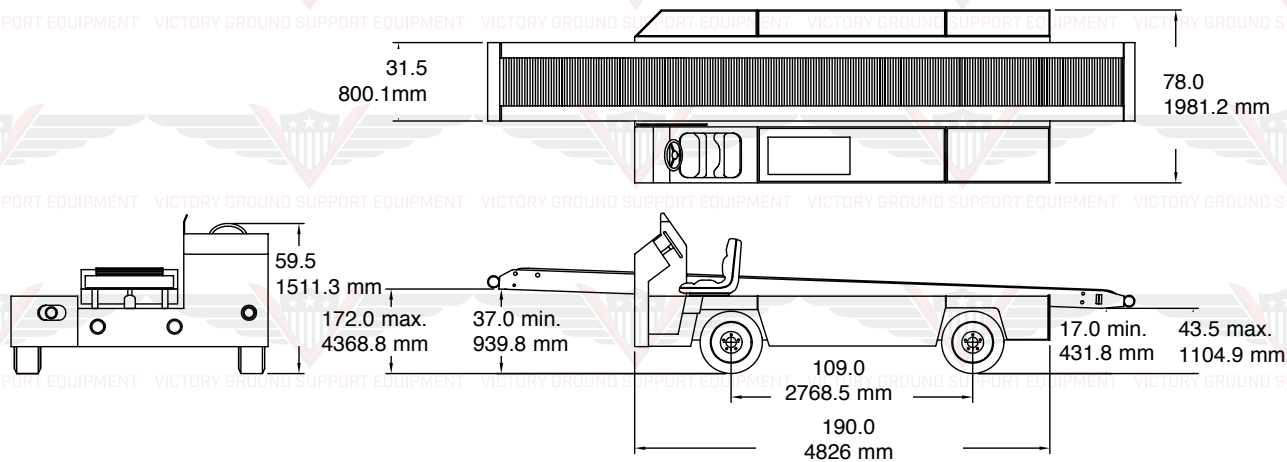

Specifications

Model 660 Mobile Belt Loader

Dimensions

Length	300" (7620 mm)
Width excluding side bumpers	78" (1981.2 mm)
Height	59" (1498.6 mm)
Wheelbase	110" (2794.0 mm)
Conveyor length less front bumper	294" (7467.6 mm)
Conveyor width less guide rails	34" (863.6 mm)
Conveyor capacity at full incline	2000 lb (907 kg)
Belt width	24" (609.6 mm)
Door sill compatibility	40 to 170" (1016.0 to 4318.0 mm)
Conveyor speed Gas & diesel	45–90 fpm (13.7 to 27.4 mpm)
Electric	10–90 fpm (3.1 to 27.4 mpm)
Gross vehicle weight	6680 lb (3030.0 kg)

Engine Options

Ford 300 Gasoline

Type	In-line, 6 cylinder
Fuel	No-lead regular, 87 octane
Bore & stroke	4 x 3.96" (101.6 x 100.6 mm)
Displacement	300 CID (4.9 L)
Governed rpm with full load	2500
Net brake hp at governed rpm	95
Torque at 2000 rpm	240 lb ft (325 Nm)
Compression ratio	7.9:1
Oil capacity Dry	7 qt (6.62 L)
Refill	6 qt (5.68 L)
Idle speed rpm	500–550

Perkins 1004 Diesel

Type	In-line, 4 cylinder
Fuel	Diesel or Jet A
Displacement	243 CID - 4 liter
Governed rpm	2500
Net brake hp at governed rpm	86
Torque at 1600 rpm	206 lb ft (279 Nm)
Compression ratio	16.5:1
Idle speed rpm	850

Deutz 1011F Diesel

Type	Air/Oil-cooled, direct injected, 4-cycle diesel engine with integrated cooling system
Fuel	Diesel or Jet A
Bore & stroke	3.6 x 4.4" (91.4 x 111.8 mm)
Displacement	167 CID

Governed rpm with full load	1800
Net brake hp at governed rpm	53
Torque at 2000 rpm	119 lb ft (161 Nm)
Compression ratio	18.5:1
Idle speed rpm	900

Transmission

Type	Ford industrial automatic transmission with torque converter
Speed	Gasoline: 2 forward, 1 reverse Diesel: 3 forward, 1 reverse
Shift Control	Shifter: 2-lever with throttle interlock

Drive Axle

Type	Dana 60 Series limited slip differential
Gear ratio	7.17:1
Suspension	Solid mount
Capacity	6000 lb (2721.1 kg)

Drive Shaft

Type	Double universal, sliding spline coupling
------	---

Electrical System

Type	12 V, negative ground
Alternator	60 A

Cooling System

Engine	15 qt (14.2 L)
	Heavy duty radiator and fan
Transmission	Radiator cooled

Fuel System

Fuel cell capacity	15.50 gal (58.67 L)
Fuel Options	Gasoline, diesel, LP or CNG

Brakes

System	Dual split system with hydraulic assist
Front	Disc
Rear	Drum
Parking	Lever operated, drum type

Steering System

Type	Orbitrol-operated hydraulic cylinder (hydrostatic steering)
------	---

Suspension

Front	Solid mount
Rear	Solid mount

Hydraulic System

Pump	positive displacement, engine belt-drive
System pressure	1500 psi max
Filter	Return line with element condition indicator
Conveyor	Electric, hydraulic power unit to raise conveyor

Instruments

Water temperature	
Oil pressure	
Hour meter	
Ammeter	
Fuel level	

Options

Electric belt control	
Extended belt length	
Guard rails	
Adjustable spot light	
Narrow conveyor width for Boeing 777 compatibility	
Emergency belt stop	
Others available upon request	

Stewart & Stevenson Tug

815 Allgood Road
Marietta, GA 30062 USA
Tel: (770) 422-7230
Fax: (770) 428-7315
TUG Shop:
(800) 989-8499 • (770) 422-8021

<http://www.sstug.com>



TUG™